

"G" Door Width _____

"A" Centerline Spread _____

"H" Door Height _____

"B" Height _____

"I" Track Projection _____

"C" Distance from Wall _____

"J" Track to Track Dist _____

"K" Outside to Outside of track _____

"L" Pit Width _____

"M" Pit to Pit Dist _____

"N" Jamb to Pit, Left _____ Right _____

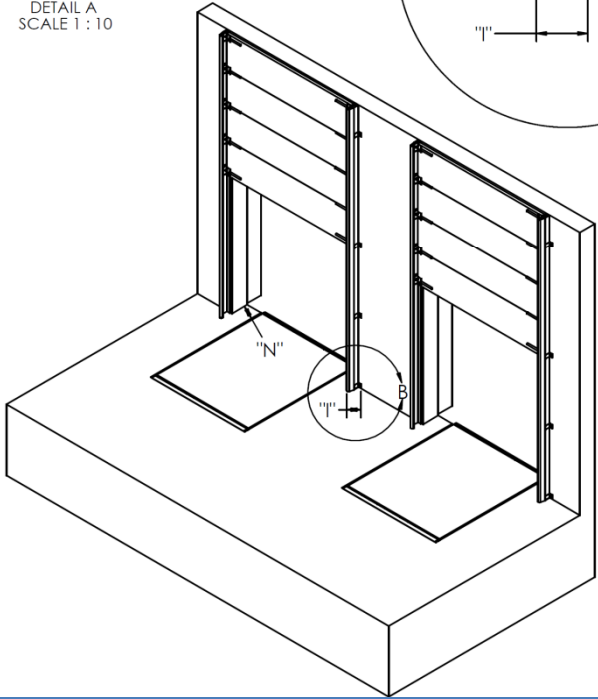
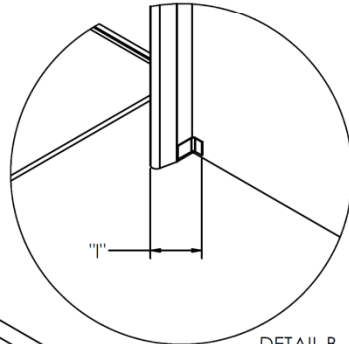
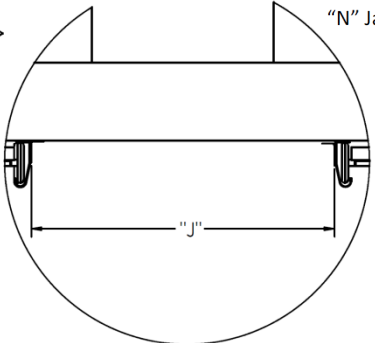

- Left Side
- Light-Manual Switch
 - Light-Auto on/off
 - Light-non switched-Direct Wired
 - Blank (no light)
- Right Side
- Light-Manual Switch
 - Light-Auto on/off
 - Light-Non Switched-Hard Wired
 - Bollard Only (no light)
- Options
- Track Guard
 - Cored In
 - Plated

"D" Left Projection _____

"E" Right Projection _____

"F" Depth _____

APPROVAL SIGNATURE
FABRICATION CAN PROCEED ACCORDING TO THE SPECIFICATIONS SHOWN, EXCEPT WHERE NOTED
PRINT NAME: _____
DATE: _____
SIGNATURE: _____

404 N Midler Ave
Syracuse, NY 13206
www.jamasenterprises.com
888-563-5356-toll free
315-463-5395-fax

BE-LIGHT TWINS APPROVAL DRAWING

CUSTOMER: _____

LOCATION: _____